



The treasure of the forests.
Energy for tomorrow.

Froling Lambdamat.
Fired with shavings and chip-
pings, with high-temperature
combustion
and Lambda
control.



A concept wins through.

The medium-size boiler range from Froling is the result of decades of experience.

Continuous development was carried out in extensive practical tests. The result: unique innovation.



Forward-looking FROLING technology extracts maximum energy from waste wood. With best possible environmental protection, optimum comfort and the highest degree of operational reliability. Technical solutions, for which FROLING has received many awards (National Award, Environmental Award).



Hi-Tec protects the environment

Waste wood contains valuable energy, which the Lambdamat optimally converts to heat.

The advantage over fossil fuel lies not only in cost savings: CO₂ that occurs when burning wood is part of the natural carbon cycle. Also, our planet is not deprived of any irreplaceable sources of energy. The Lambdamat's extremely clean combustion also ensures that even the strictest current and future emission control regulations are met comfortably.

Save better heating

Maximung operational reliability and simple maintenance have top priority with FROLING.

Hence the extremely solid design, which ensures problem-free and faultless operation for many years. The FROLING safety system: 4-fold backfire protection through backfire damper or cellular wheel sluice in conjunction with pressure well, vacuum control and sprinkler system, and combustion chamber temperature monitoring to protect the fireclay combustion chamber against unacceptably high temperature.

Feed grate

Feed grate for automatic ash removal.

The Lambdamat is equipped with highly modern feed grate technology. This means automatic grate cleaning and ash removal - and therefore largely maintenance-free operation.

Only 5 % higher initial cost, but 98 % more comfort. Possible with the new FROLING Lambdamat.



**Unique:
Service and
control by
telephone
and PC.**

Remote maintenance

Service and control by telephone and PC.

From now on, all setting parameters can also be changed and interrogated by PC or in connection with a modem via telephone.

This offers 2 great advantages:

Control and any necessary adjustments to the system can be made without problems from the office or home. And system optimisation and maintenance be done directly by FROLING via telephone modem, saving time and money.

Automatic control

The computer ensures controlled operation. The entire system is constantly optimised and monitored:

- permanent combustion optimisation by flue gas analysis
- output and vacuum control
- automatic adaption to fuels
- combustion chamber temperature monitoring
- temperature differential control
- PC-visualisation and data capture (trend analysis)

The menu-driven operator surface enables simple modification of the settings. Additionally, various data like flue gas temperature, residual oxygen content, feed and return flow temperature, etc. can readily be interrogated.

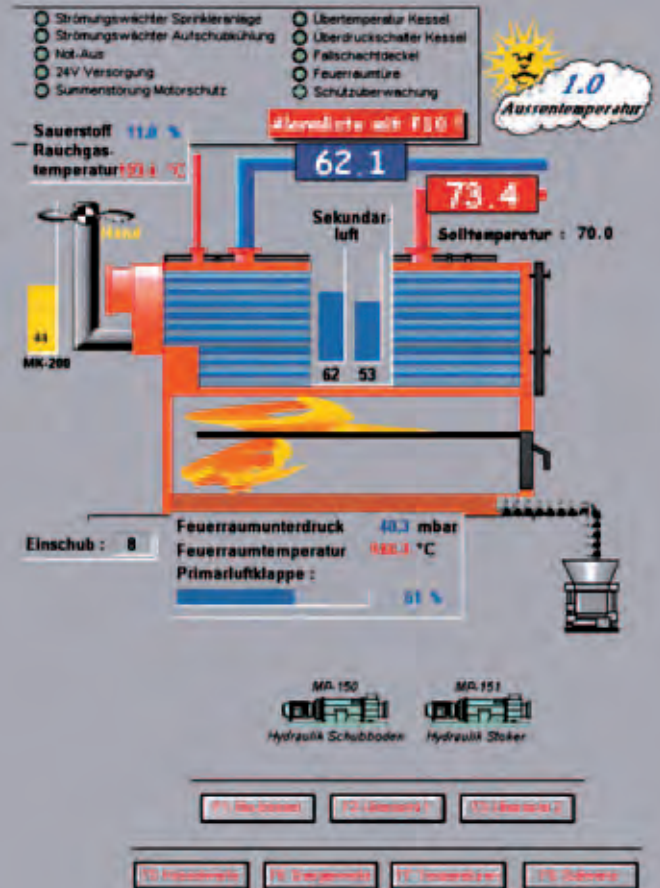

4 Shells

Up to 90 % efficiency.

This is unique: The Lambdamat's high-temperature vortex chamber is constructed of 4 shells, thereby achieving highest possible efficiency and cleanest possible combustion. A concept that leaves nothing to be desired.

A concept that leaves nothing to be desired.

Combustion technology and plant system are determined by the grain size and moisture content of the fuel. FROLING offers a tailor-made solution for every applicaiton

FROLING Lambdamat Industrial. Hi-Tec in the smallest place

Besides innovation, this boiler technology for fuels up to a grain size to ÖNORM G 50 and a moisture content of 40 % also features extremely compact dimensions. Bringing in presents no problem even under difficult conditions.

The boiler is delivered in two parts. The variable stoker connection, which on the left-hand or right-hand side or at the back facilitates simple connection to the feed systems even under unfavourable installation condidtions.

Combustion chamber geometry, grate technology and air routes are ideally matchet to the combustion of the intended fuel. The movable feed grate ensures uniform burn-down and, in connection with automatic ash removal, maintenance-free operation. The combustion chamber is lined with modular system fireclay bricks. The individual bricks are readily replaceable, if worn.

The multi-way heat exchanger mounted on top of the combustion chamer has generously sized heat exchanger surfaces. Large an easily accesible cleaning and maintenance apertures ensure ease of maintenace.

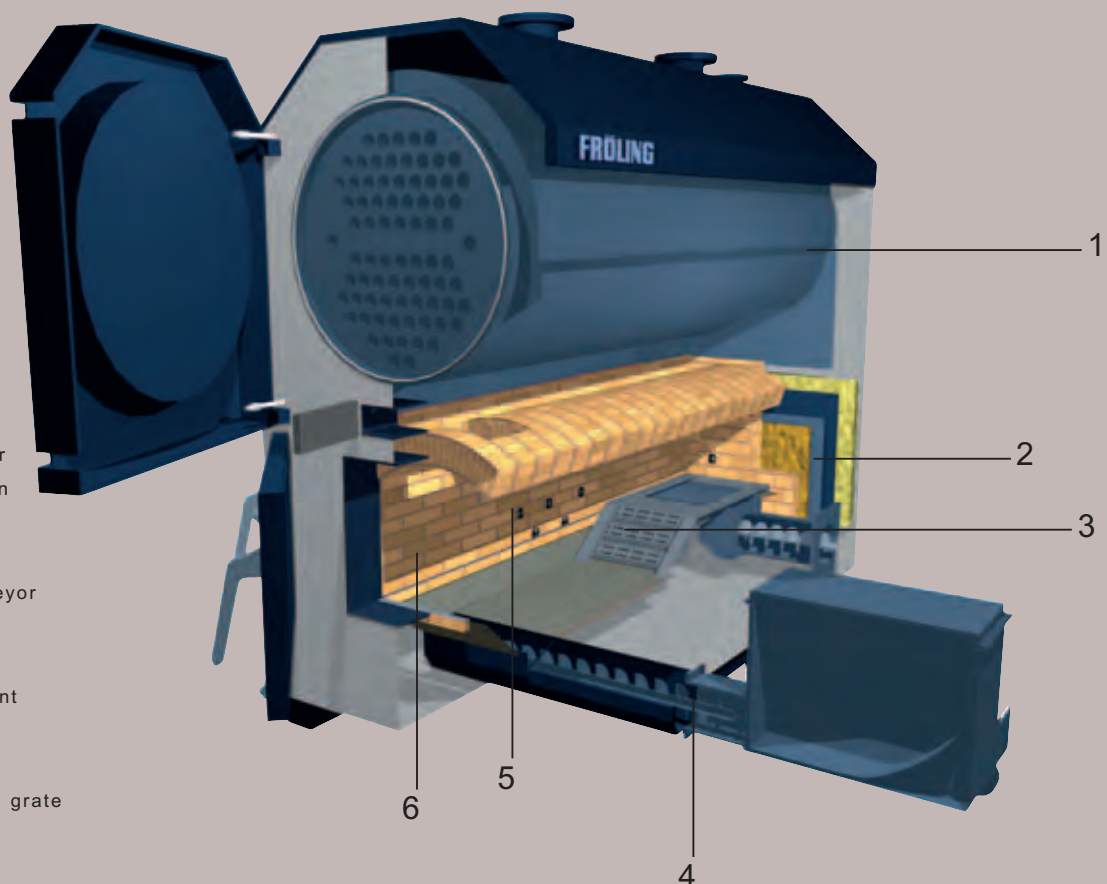

Lambdamat Industrial

- 1 Multi-way heat exchanger
- 2 4-shell retort construction
- 3 Moving feed grate with primary air intake
- 4 Ash removal screw conveyor and ash container
- 5 Secondary air apertures
- 6 High-temperature resistant fireclay retort

Lambdamat Communal

- 7 Hydraulically moved feed grate with primary air intake
- 8 Tertiary air apertures
- 9 Twin-tunnel vault

FROLING Lambdamat Communal. Hi-Tec without limits.

This concept is also suitable for burning moist fuel (50 % and more water content) with a high proportion of bark. The hydraulically moved feed grate or step grate extending over the entire length of the retort continuously transport the fuel to the combustion chamber until complete burn-out is achieved even with the most difficult fuel. The burnt-out ash is automatically discharged via ash removal screw conveyors or directly into an ash container. The combustion chamber geometry is optimally matched to burning moist fuel. Besides the fuel feed by screw conveyor, this boiler technology is also available with hydraulic feed systems, ensuring problem-free operation with fuel of a grain size to ÖNORM G 100.

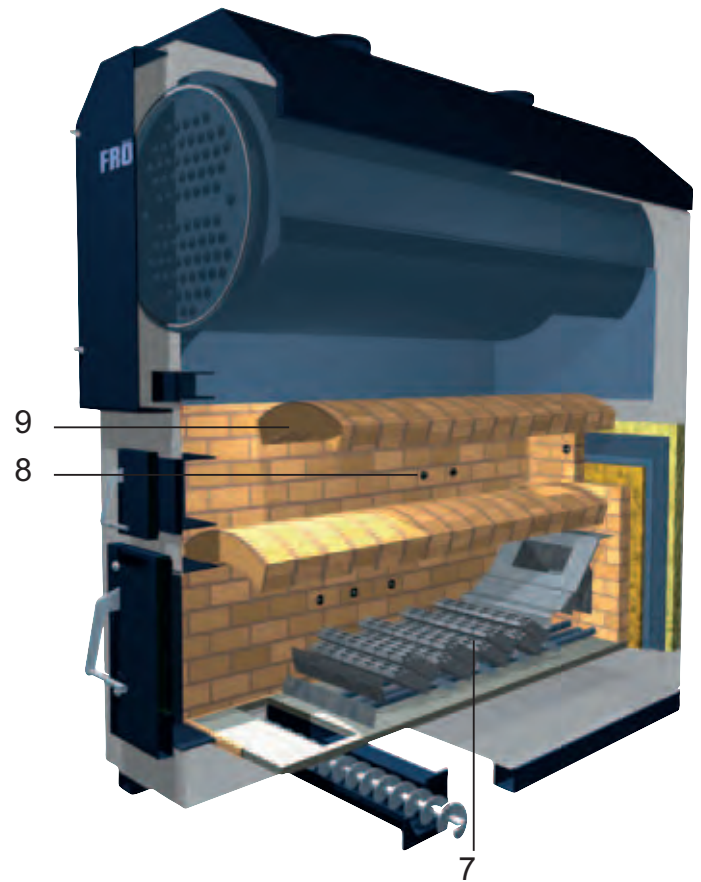

Everything fed cleverly.

No matter whether large or small systems, besides these innovative boiler concepts FROLING also supplies a wide range of feed systems of the highest technical standard. The selection ranges from a simple floor agitator for low store rooms (max. 6 x 6 m flow area), screw-type elevators or horizontal screw conveyors for tower silos (max. 8 x 8 m diameter) to push rod discharge for rectangular store rooms with large floor area.

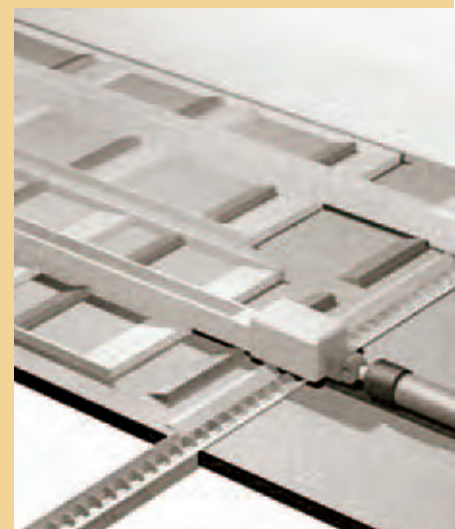
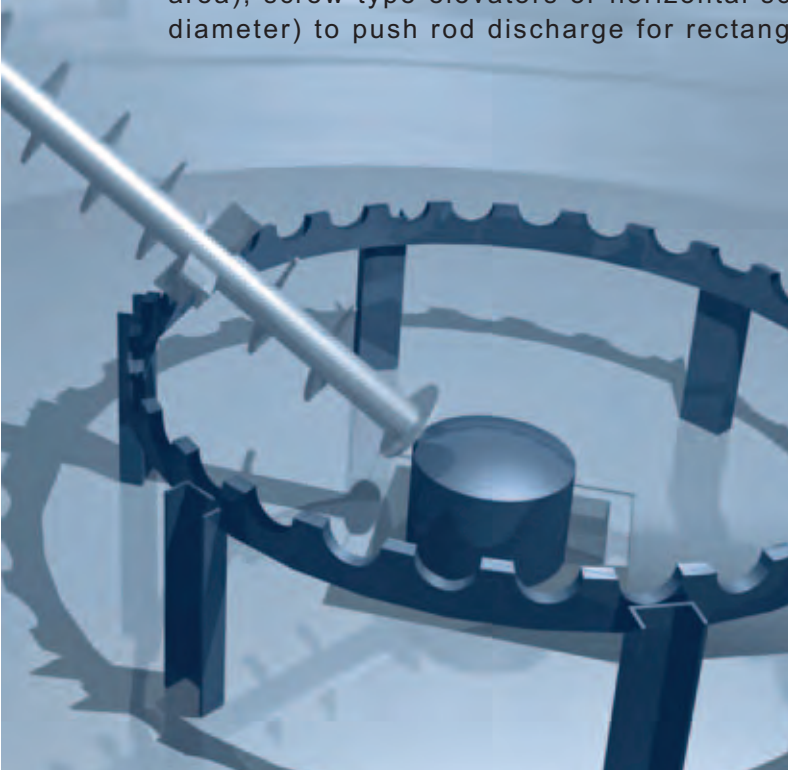

Lambdamat

80 – 1000 kW

Technical data, dimensions:

Boiler	Lambdamat	Lambdamat	Lambdamat
	Industrial	Industrial	Industrial/Communal
	150	220	320/320
Output kW	80-150	150-200	200-300/200-300
Length l	2165	2715	2715/2715
Width b	930	1070	1070/1070
Hight h	2030	2300	2300/2802
Fire tube dia	200	250	300/300

Boiler	Lambdamat	Lambdamat	Lambdamat
	Industrial/Communal	Industrial/Communal	Communal
	500/500	750/750	1000
Output kW	320-500/320-500	500-750/500-750	750-1000
Length l	2760/2710	3070/3070	3740
Width b	1270/1270	1500/1630	1630
Hight h	2550/3224	2930/3656	3910
Fire tube dia	350/350	400/400	450

Other sizes on request.

FROLING. The complete provider.

FROLING supplies all components connected with a heating system, e.g. fabricated high-grade steel chimneys, dust collectors or flue gas purification, automatic cleaning equipment for the heat exchanger surfaces of the fire tube boiler, chopping machines for wood waste, briquette-making systems and much more.



Heizkessel- und Behälterbau Ges.m.b.H.
A-4710 Grieskirchen, Industriestraße 12
Tel. +43(0)7248-606, Fax +43(0)7248-606-600
E-Mail: info@froeling.com
www.froeling.com